

Broaden the Operation Window for a Batch Distillation

Jan Schöneberger¹, Burcu Aker¹, Armin Fricke¹, Michael Kawohl², Christoph Hiller², Valentin Khaydarov³

¹Capital-Gain Consultants, ²Evonik, ³AI-incubator lab at TU Dresden

Distillation column

Setup

- Well equipped distillation column
- Online analysers

Operation scenarios

- Continuous operation
- Batch operation
- Dedicated failure scenarios (flooding)

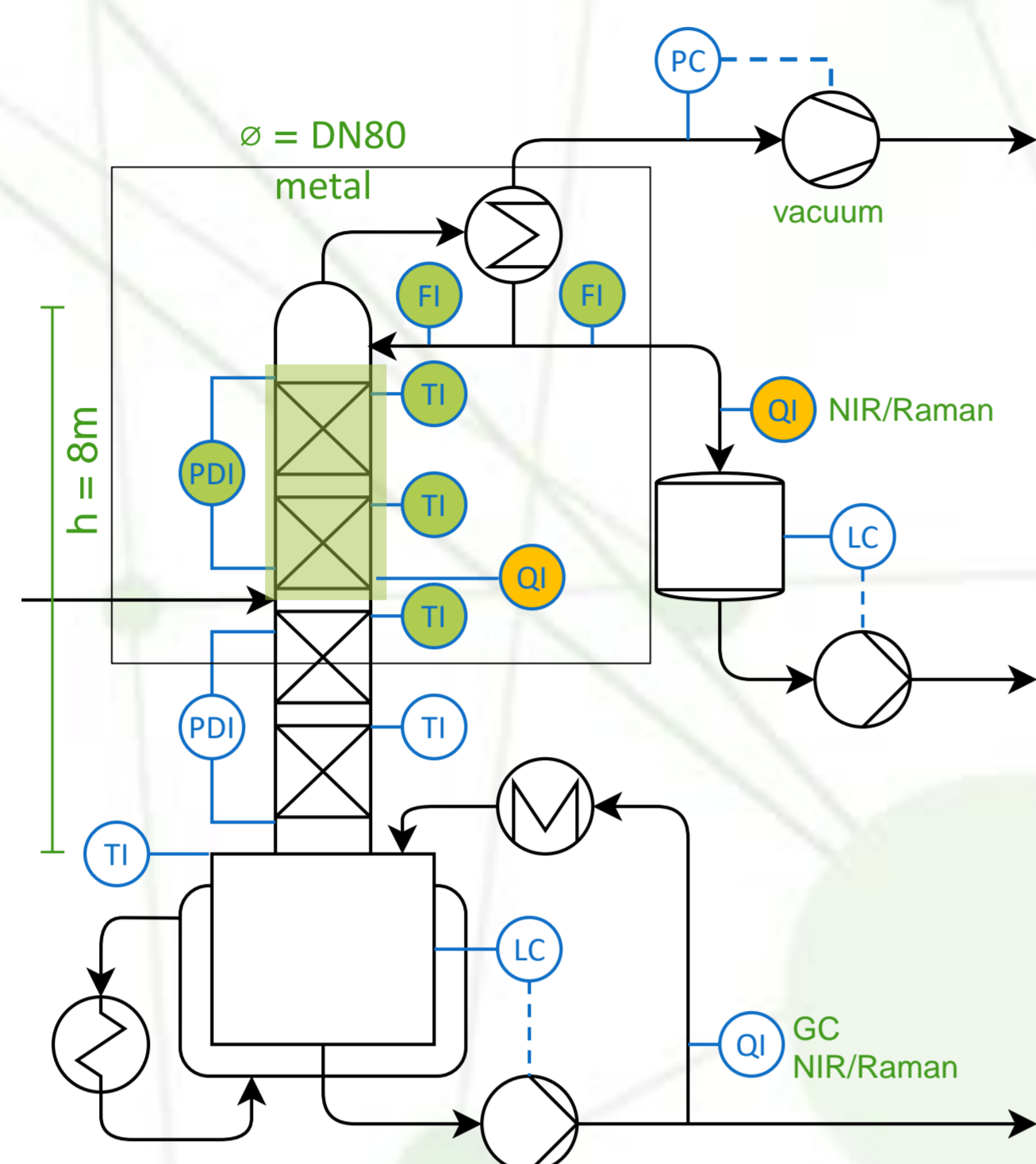

Use case description

Flooding – common suboptimal process condition wherein the separation performance is significantly reduced due to excessive vapour flow. It is detected by a sharp increase in **column differential pressure**.

How can we put the measured variables (mainly pressure drop) into correlation with the product quality?

Goal: **hybrid description of multidimensional non-orthogonal operation window of batch distillation column**

Data: substance composition at inlet and outlet, pressure difference, liquid and vapour flow rates, temperatures, reboiler duty

Load dependent separation efficiency

F-factor (gas load factor) as an important measure

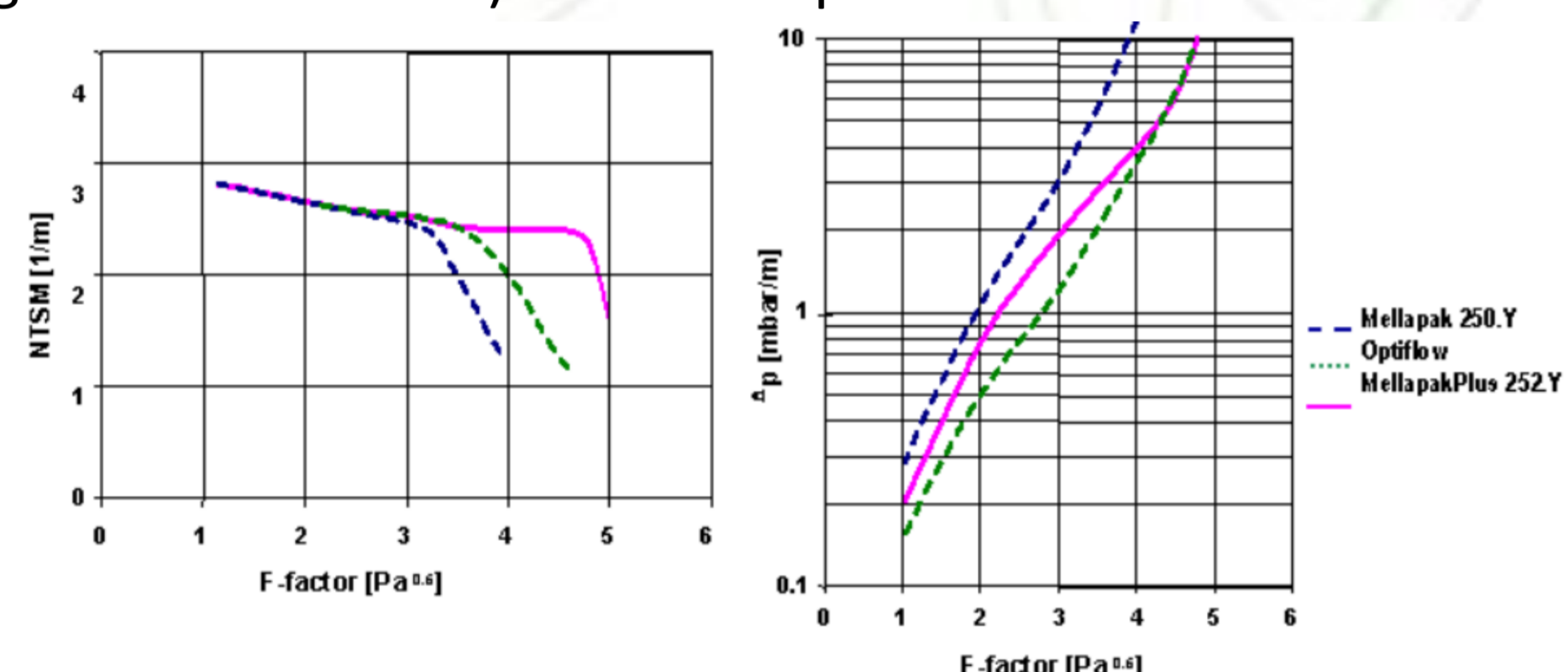

$$\frac{\Delta p}{NTU_{OV}} S_{CV}^{-2/3} = A \left(\frac{L}{V}\right)^n F_V^{m1} \quad [2]$$

Various models for both dependencies are available. However, generalized pressure drop correlations are normally accurate to only within 20% [3].

Transfer learning

- Generation of synthetic data based on empirical correlations
- Training a generic surrogate model based on synthetic data
- Fine tuning model to represent the real process

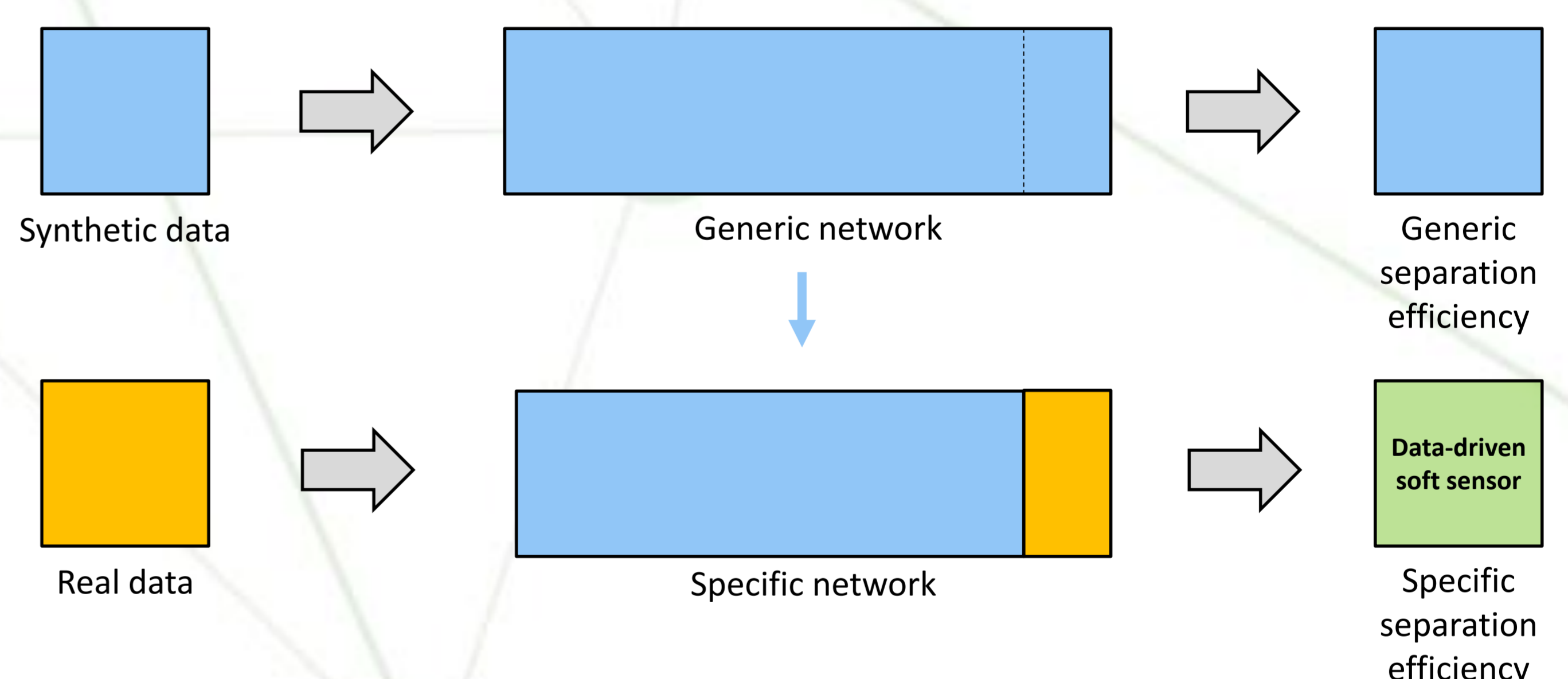

Show real separation efficiency to the operator

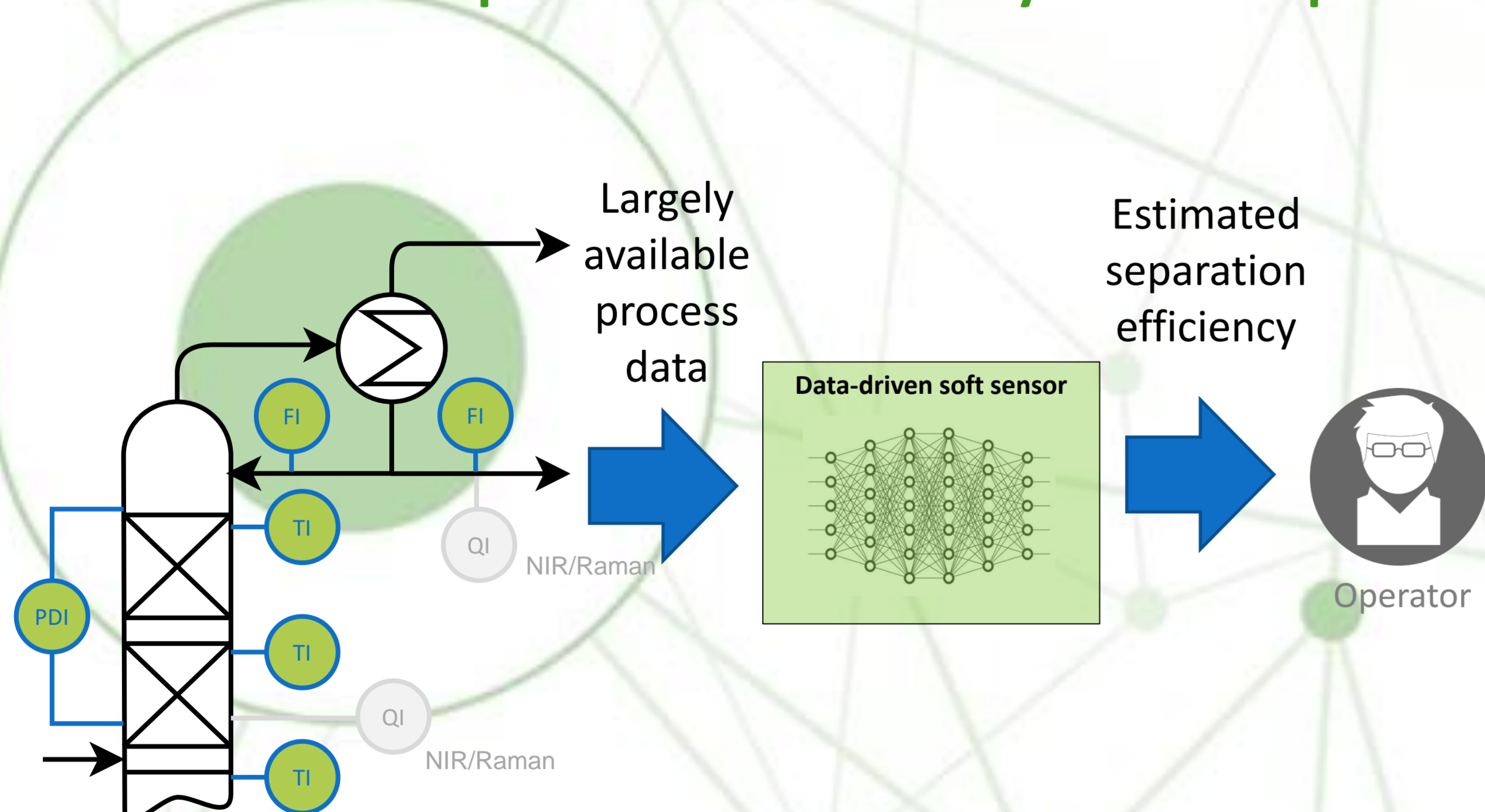

Roadmap

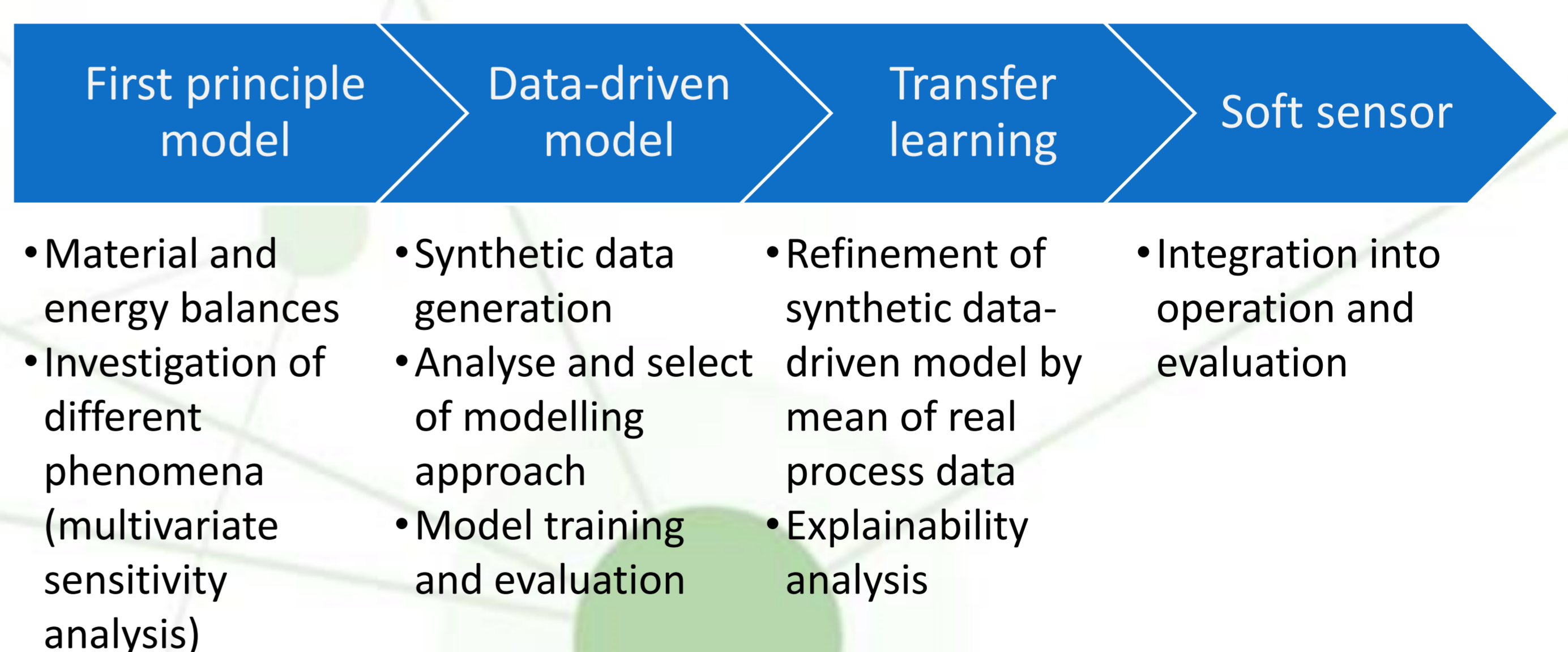

[1] Spiegel, L., & Meier, W. (2003). Distillation columns with structured packings in the next decade. Chemical Engineering Research and Design, 81(1), 39–47. <https://doi.org/10.1205/026387603321158177>

[2] Billet, R. (2005). Packed towers: In processing and environmental technology. In Packed Towers: In Processing and Environmental Technology. <https://doi.org/10.1002/3527605983>

[3] HAT International. (2011). AlphaPACK® DESIGN SHEET - Random Packing.